



Battery Guard

-

BG30 / BG60 / BG200

Where?

The Battery Guard is designed to prevent excessive discharge of your battery caused by the consumers. It also prevents excessive voltage caused by a faulty alternator or charger which could damage the connected consumers. When your battery is discharged excessively it will not be possible to start the engine and also shortens the lifespan of the battery.

How?

The Battery Guard is a Microprocessor controlled, solid state, switch (FET). The battery voltage is constantly measured and an alarm output will be activated when the battery voltage is too low for 15 seconds. This alarm output can be connected to a buzzer or small lamp. If there are no changes within the next minute the Battery Guard will disconnect the consumers; the alarm will be discontinued. When the battery voltage is much too high the consumers will be disconnected immediately and the alarm (contact) will be activated alternating on and off.

The Battery Guard is adjustable for 12V or 24V systems. Also there is a choice of four preprogrammed voltage levels for 12V and four for 24V. There is also the possibility of programming other voltages.

Why?

Excessive discharge will shorten the live span of a battery considerably. The Battery Guard prevents excessive discharge of the battery. Therefore it will always be possible to start the engine. Also it prevents damage to the connected consumers due excessive voltage caused by a faulty alternator or charger.

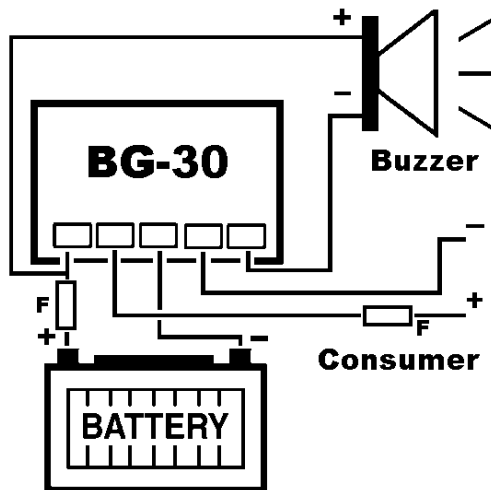

Battery Guard	BG30	BG60	BG200 *	
Continues current	25	60	200	A
Input voltage	6-35	6-35	*	V
Standby current	< 7mA	< 7mA	*	V
Max. current alarm output	500mA	500mA	*	
Weight	0,2	0,2	*	kg
Dimensions (h x w x d)	49*88*68	80*60*40	*	mm

* Introduction 2005

Jumper settings	12V on	12V off	24V on	24V off
1	10V	11,5V	21,5V	24,5V
2	10,5V	12V	22V	25V
3	11V	13V	22,5V	25,5V
4	11,5V	13,8V	23V	26,5V